

Arduino Nano (V2.2)

User Manual

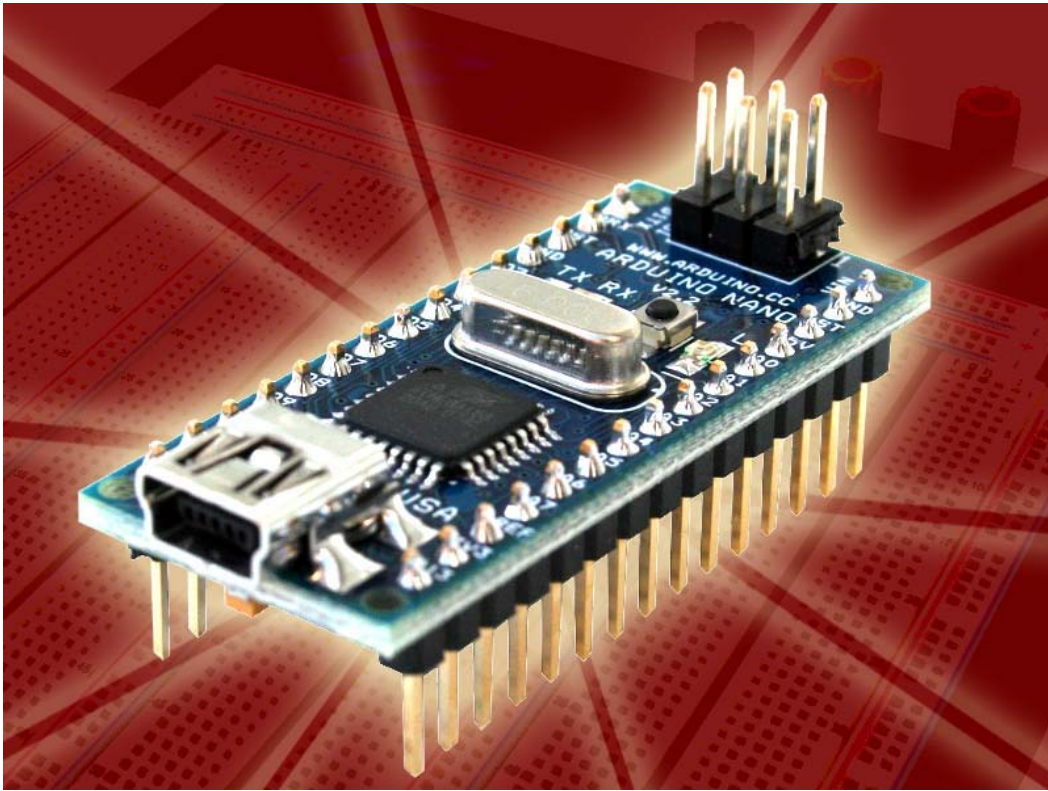

Released under the Creative Commons Attribution Share-Alike 2.5 License

<http://creativecommons.org/licenses/by-sa/2.5/>

More information:

www.arduino.cc

Rev. 2.2

Arduino Nano Pin Layout

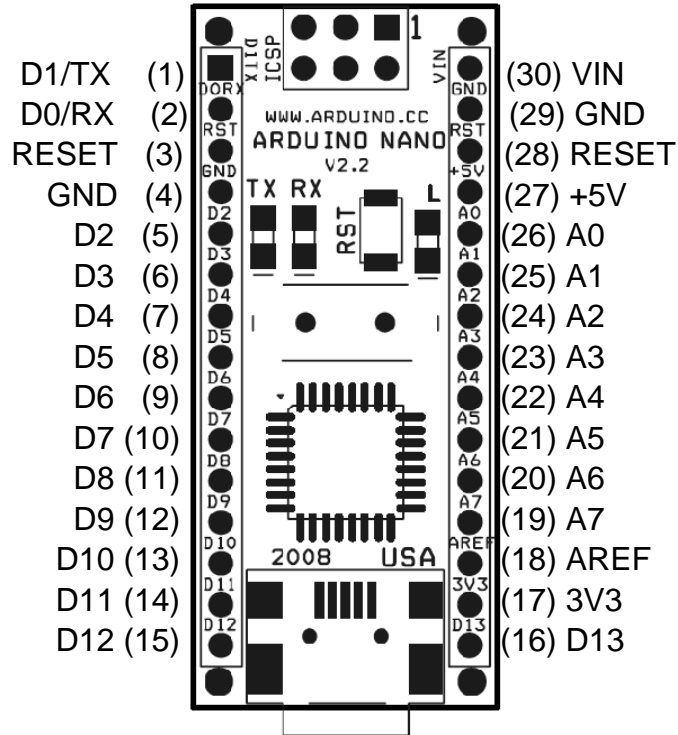

Pin No.	Name	Type	Description
1-2, 5-16	D0-D13	I/O	Digital input/output port 0 to 13
3, 28	RESET	Input	Reset (active low)
4, 29	GND	PWR	Supply ground
17	3V3	Output	+3.3V output (from FTDI)
18	AREF	Input	ADC reference
19-26	A7-A0	Input	Analog input channel 0 to 7
27	+5V	Output or Input	+5V output (from on-board regulator) or +5V (input from external power supply)
30	VIN	PWR	Supply voltage

Arduino Nano Mechanical Drawing

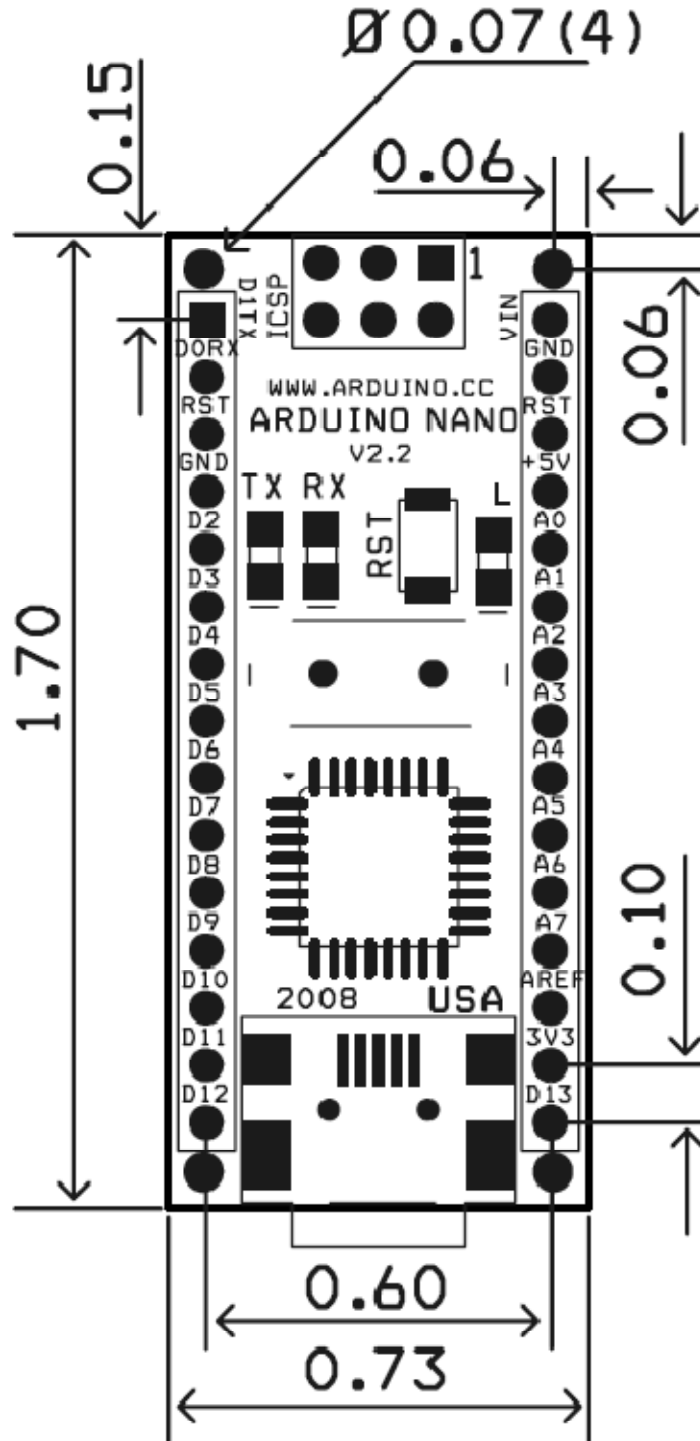

ALL DIMENSIONS ARE IN INCHES

Arduino Nano Bill of Material

Item Number	Qty.	Ref. Dest.	Description	Mfg. P/N	MFG	Vendor P/N	Vendor
1	5	C1,C3,C4,C7,C9	Capacitor, 0.1uF 50V 10% Ceramic X7R 0805	C0805C104K5RACTU	Kemet	80-C0805C104K5R	Mouser
2	3	C2,C8,C10	Capacitor, 4.7uF 10V 10% Tantalum Case A	T491A475K010AT	Kemet	80-T491A475K010	Mouser
3	2	C5,C6	Capacitor, 18pF 50V 5% Ceramic NOP/COG 0805	C0805C180J5GACTU	Kemet	80-C0805C180J5G	Mouser
4	1	D1	Diode, Schottky 0.5A 20V	MBR0520LT1G	ONsemi	863-MBR0520LT1G	Mouser
5	1	J1,J2	Headers, 36PS 1 Row	68000-136HLF	FCI	649-68000-136HLF	Mouser
6	1	J4	Connector, Mini-B Recept Rt. Angle	67503-1020	Molex	538-67503-1020	Mouser
7	1	J5	Headers, 72PS 2 Rows	67996-272HLF	FCI	649-67996-272HLF	Mouser
8	1	LD1	LED, Super Bright RED 100mcd 640nm 120degree 0805	APT2012SRCPRV	Kingbright	604-APT2012SRCPRV	Mouser
9	1	LD2	LED, Super Bright GREEN 50mcd 570nm 110degree 0805	APHCM2012CGCK-F01	Kingbright	604-APHCM2012CGCK	Mouser
10	1	LD3	LED, Super Bright ORANGE 160mcd 601nm 110degree 0805	APHCM2012SECK-F01	Kingbright	04-APHCM2012SECK	Mouser
11	1	LD4	LED, Super Bright BLUE 80mcd 470nm 110degree 0805	LTST-C170TBKT	Lite-On Inc	160-1579-1-ND	Digikey
12	1	R1	Resistor Pack, 1K +/-5% 62.5mW 4RES SMD	YC164-JR-071KL	Yageo	YC164J-1.0KCT-ND	Digikey
13	1	R2	Resistor Pack, 680 +/-5% 62.5mW 4RES SMD	YC164-JR-07680RL	Yageo	YC164J-680CT-ND	Digikey
14	1	SW1	Switch, Momentary Tact SPST 150gf 3.0x2.5mm	B3U-1000P	Omron	SW1020CT-ND	Digikey
15	1	U1	IC, Microcontroller RISC 16kB Flash, 0.5kB EEPROM, 23 I/O Pins	ATmega168-20AU	Atmel	556-ATMEGA168-20AU	Mouser
16	1	U2	IC, USB to SERIAL UART 28 Pins SSOP	FT232RL	FTDI	895-FT232RL	Mouser
17	1	U3	IC, Voltage regulator 5V, 500mA SOT-223	UA78M05CDCYRG3	TI	595-UA78M05CDCYRG3	Mouser
18	1	Y1	Cystal, 16MHz +/-20ppm HC-49/US Low Profile	ABL-16.000MHZ-B2	Abracon	815-ABL-16-B2	Mouser

Arduino Nano Schematic

Copyright 2008 under the Creative Commons Attribution Share-Alike 2.5 License
<http://creativecommons.org/licenses/by-sa/2.5/>

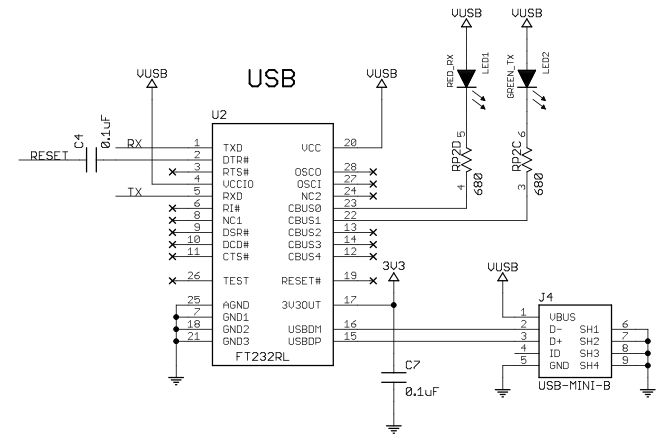
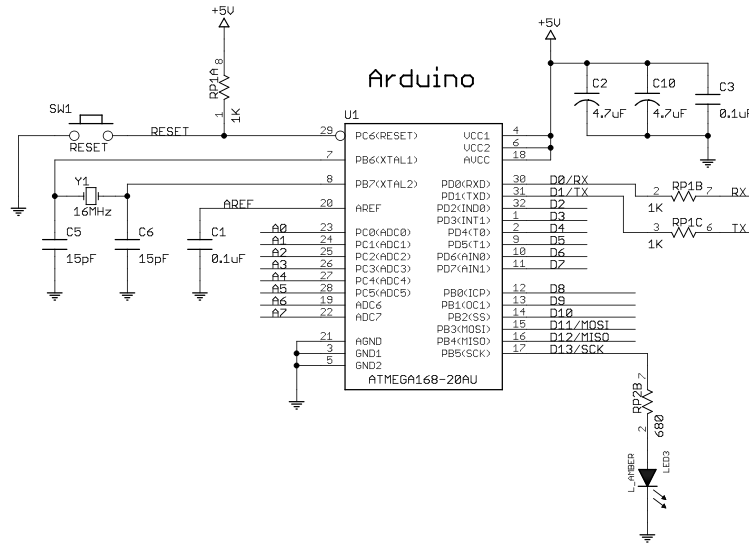
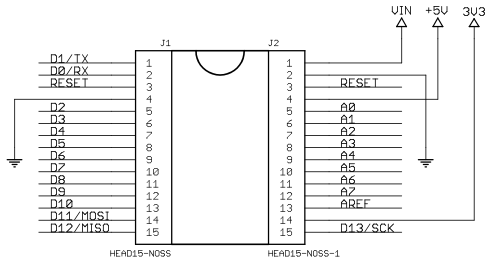

+5V AREF OPTION

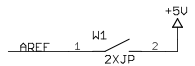

+5V REG

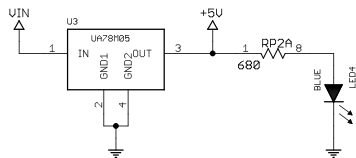

+5V AUTO SELECTOR

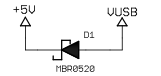

NOT USED

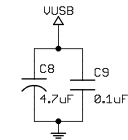
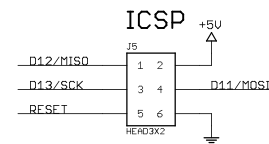
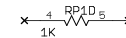

TITLE: Arduino Nano	
Document Number:	REV: 2.2
Date: 5/7/2008 7:46:22 PM	Sheet: 1/1

Arduino Nano Pictures

